

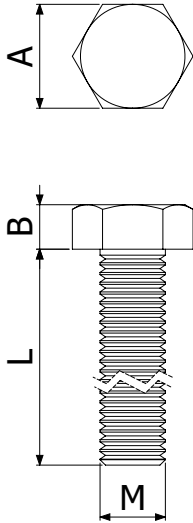

CHARACTERISTICS



Models: 6x25;8x20; 8x25; M10x20; M10x30.

Finishes: EZ, ss304, ss316.

Characteristics:

- Hexagon Nut (mounting wrench)

Dimensions:

MODEL	M(mm)	L (mm)	A (mm)	B (mm)	T (N-m)
M6x25	6	25	10	4	8
M8x20	8	20	13	5,3	15
M8x25	8	25	13	5,3	15
M10x20	10	20	17	6,4	35
M10x25	10	25	17	6,4	35
M10x30	10	30	17	6,4	35

USE INSTRUCTIONS

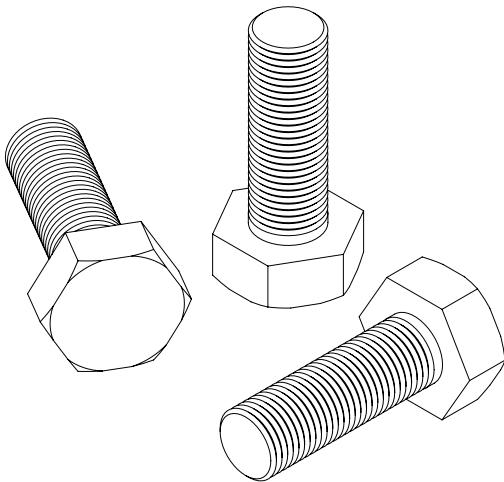

- Its most common use in BASOR's range of products is the attachment of ladders to supports and the assembling of profiles and accessories of the 41/82 range. For this use they are used together with spring or non-slip nuts.
- Bolts shall be used together with DIN 934 nuts and washers DIN 125 or DIN 9021, except in open profile assemblies.